



Conductive Level

Top Mounted Conductivity Switches for Liquid Level

Principle

Conductive level switches operate by using the liquid in your vessel to complete an electrical circuit. Several electrodes (one for each switch point you need) extend into your vessel. As the liquid rises up, it bridges the gap between the electrodes, completing the circuit and closing relays.

Advantages

- No moving parts - works well on liquids with suspended solids

Disadvantages

- Does not work with solids
- Only works with conductive liquids (eg. will not work on fuel or oil).
- Not suitable for coating liquids such as paints.

Considerations

For metal tanks you only require one electrode per switch point, as the tank itself acts as one of your electrodes. If you are using a plastic or similar non-conductive tank, your sensor needs to include an additional 'source' electrode.

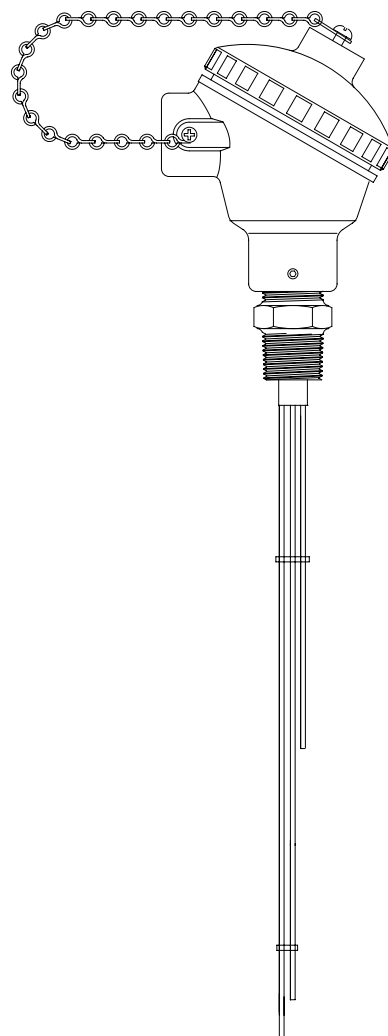
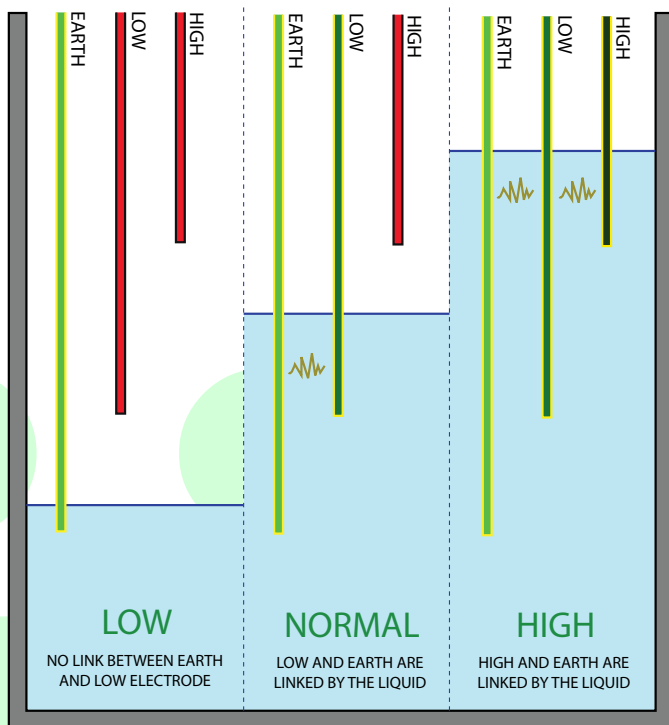

RIGHT: A drawing of a custom-made conductive level switch

ABOVE: An example of the operation of a conductive level switch detecting low and high level in a plastic tank.